

# REBEL™ POOL LIFT

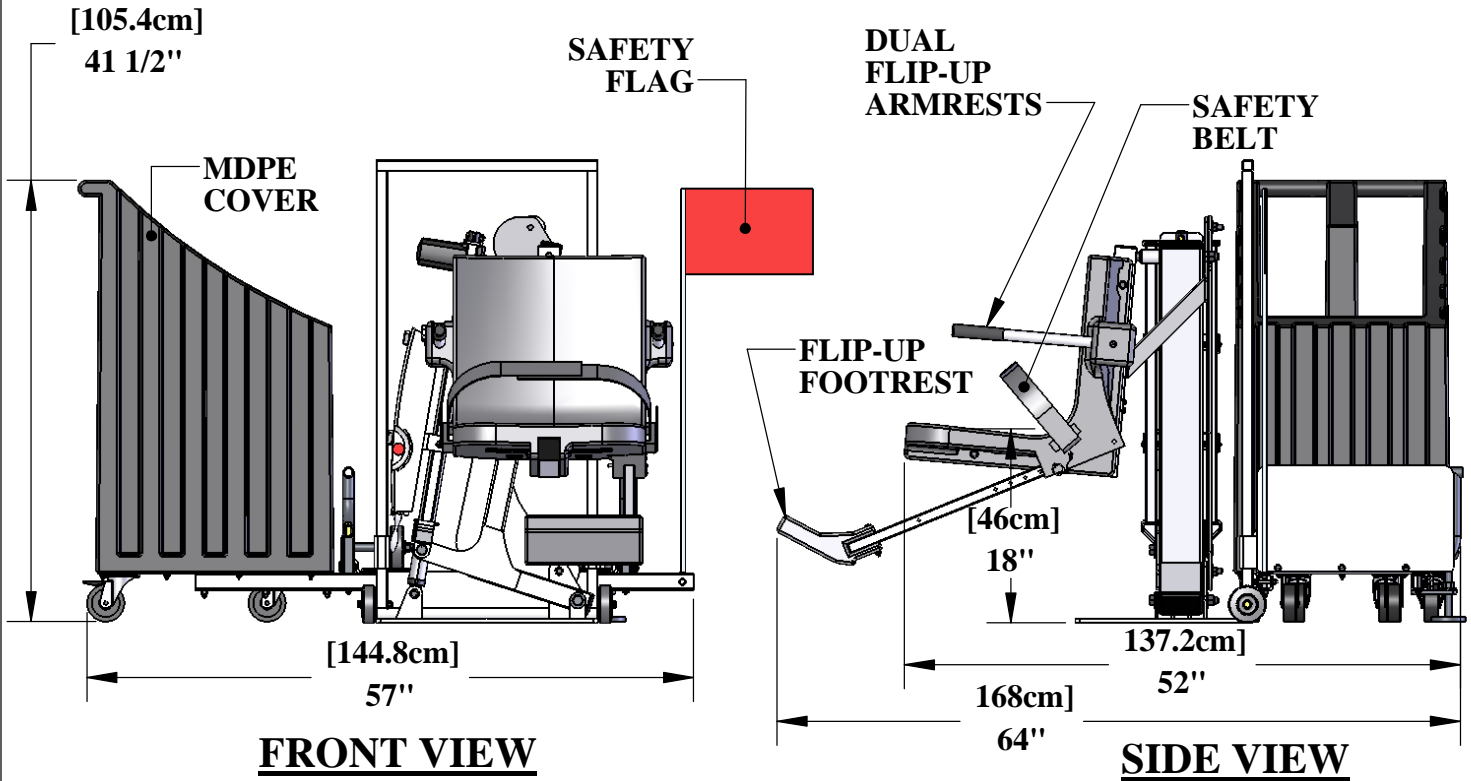

## SPECIFICATIONS:

THE AQUA CREEK PRODUCTS' REBEL POOL LIFT SHALL BE AN ADA COMPLIANT FULLY PORTABLE POOL LIFT. IT SHALL HAVE A MAXIMUM LIFTING CAPACITY OF 300LBS (136 kg). IT SHALL INCORPORATE A SLIDING MECHANISM ALLOWING THE LIFT TO BE STORED ON TOP OF THE FRAME FOR TRANSPORTATION WITHOUT REQUIRING ANY DISSASSEMBLY OR TOOLS. IN THE TRANSPORT CONFIGURATION, THE ASSEMBLY SHALL BE CAPABLE OF BEING ROLLED THROUGH A STANDARD 36" WIDE DOORWAY. ALL METAL COMPONENTS SHALL BE MADE OF TYPE 304 STAINLESS STEEL, AND SHALL BE POWDER COATED FOR ADDITIONAL CORROSION RESISTANCE. THE COVER, SEAT AND FOOTREST SHALL BE MADE FROM ROTOMOLDED POLYETHYLENE. ALL OTHER PLASTIC PARTS SHALL BE MADE FROM HIGH-DENSITY POLYETHYLENE. DUAL FLIP-UP ARMRESTS, A FLIP-UP FOOTREST AND A SAFETY BELT SHALL COME AS STANDARD EQUIPMENT. THE REBEL POOL LIFT SHALL CARRY A LIMITED 2-YEAR WARRANTY.

- FRAME: 1-1/2" x .180" WALL SQR. TUBING, TYPE 304 S.S.
- BASE PLATE: 3/8" THK. PLATE, TYPE 304 S.S.
- COVER: ROTOMOLDED MDPE (MEDIUM DENSITY POLYETHYLENE)
- CASTERS: Ø 3-1/2" RUBBER WHEEL, STAINLESS STEEL FRAME (2 WITH BRAKES)

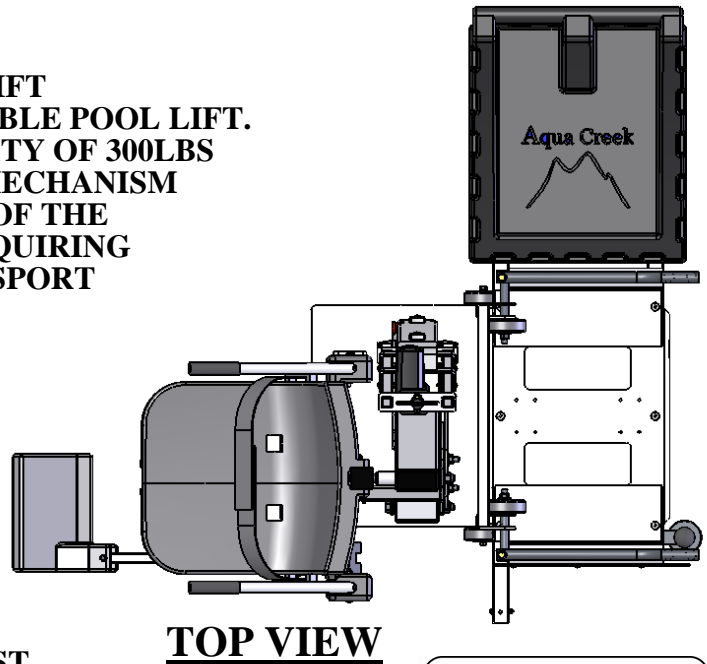

Inspected And Verified To Meet  
Applicable Sections of ADA  
Guidelines Section 1009.2 By

**wyle**  
laboratories

A Nationally Recognized  
Test Laboratory

**Aqua Creek Products**

The Total Solution for Pool and Spa Access

9889 GARRYMORE LANE  
MISSOULA, MT 59808  
(406) 549-0769  
FAX (406) 549-2602

NOTE:  
\*SPECIFICATIONS ARE SUBJECT TO CHANGE WITHOUT NOTICE

PRODUCT:	F-2PR	
DWG #:	F-2PR-1	
SCALE:	1:24	DATE: 10/3/11
DRAWN BY:	DS	REVISION: B

# REBEL™ POOL LIFT

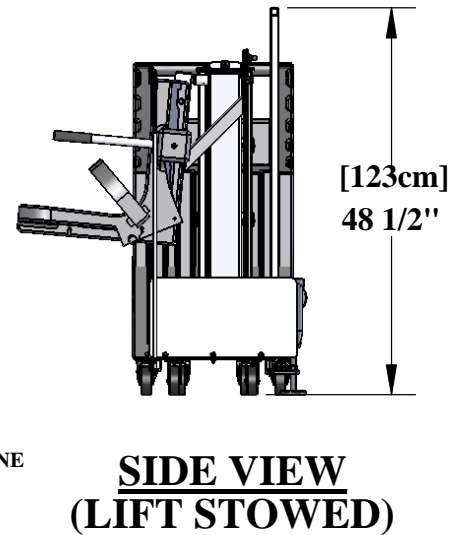
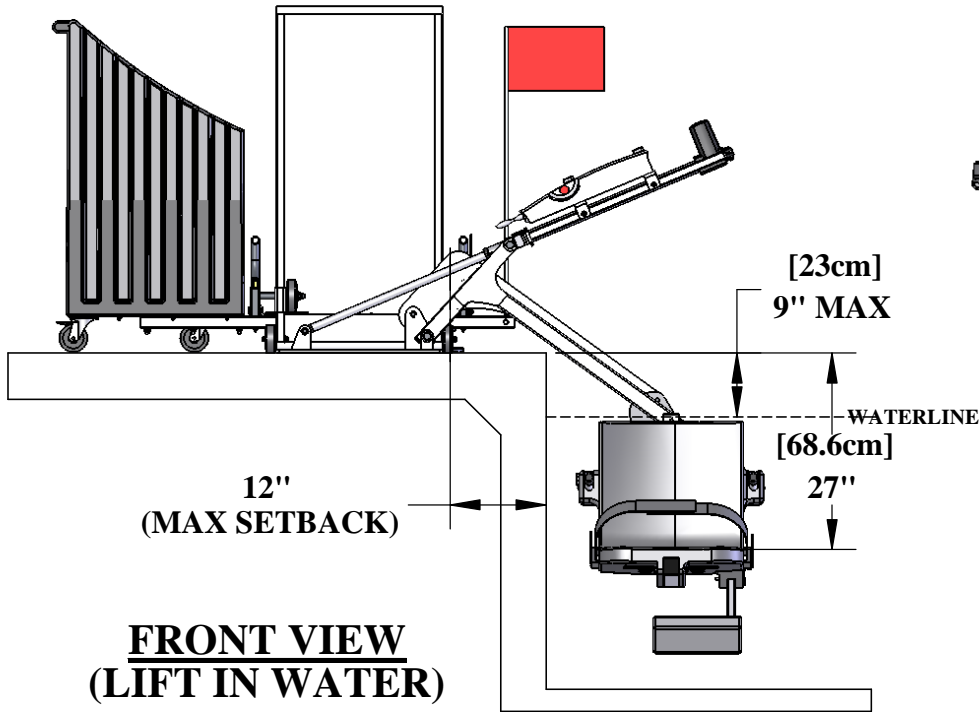
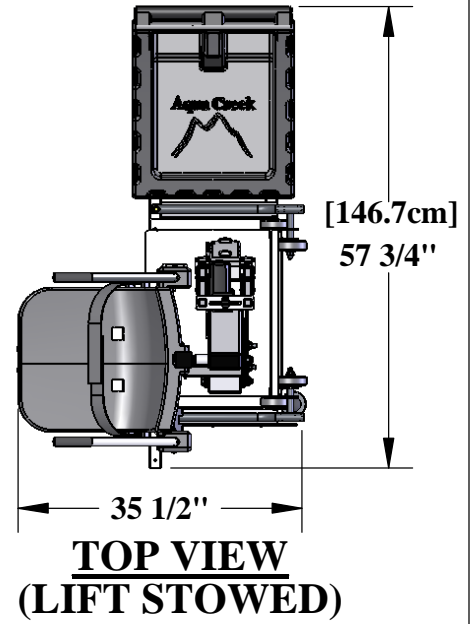
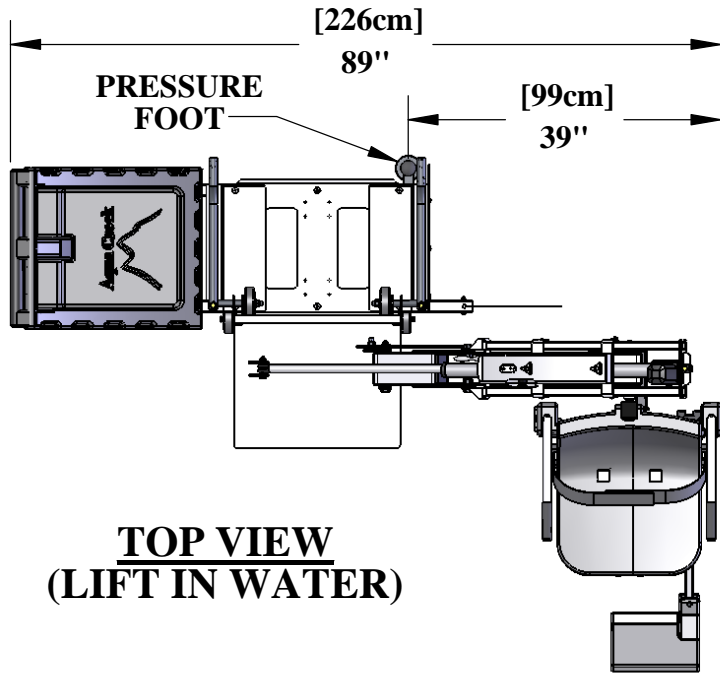

Inspected And Verified To Meet  
Applicable Sections of ADA  
Guidelines Section 1009.2 By

**wyle**  
laboratories

A Nationally Recognized  
Test Laboratory

9889 GARRYMORE LANE  
MISSOULA, MT 59808  
(406) 549-0769  
FAX (406) 549-2602

NOTE:  
\*SPECIFICATIONS ARE SUBJECT TO CHANGE WITHOUT NOTICE

PRODUCT:	F-2PR	
DWG #:	F-2PR-2	
SCALE:	1:24	DATE: 10/3/11
DRAWN BY:	DS	REVISION: B

**Aqua Creek Products**  
The Total Solution for Pool and Spa Access